

DRSA-Biltz - Circular Chaser Head

Component Parts Breakdown

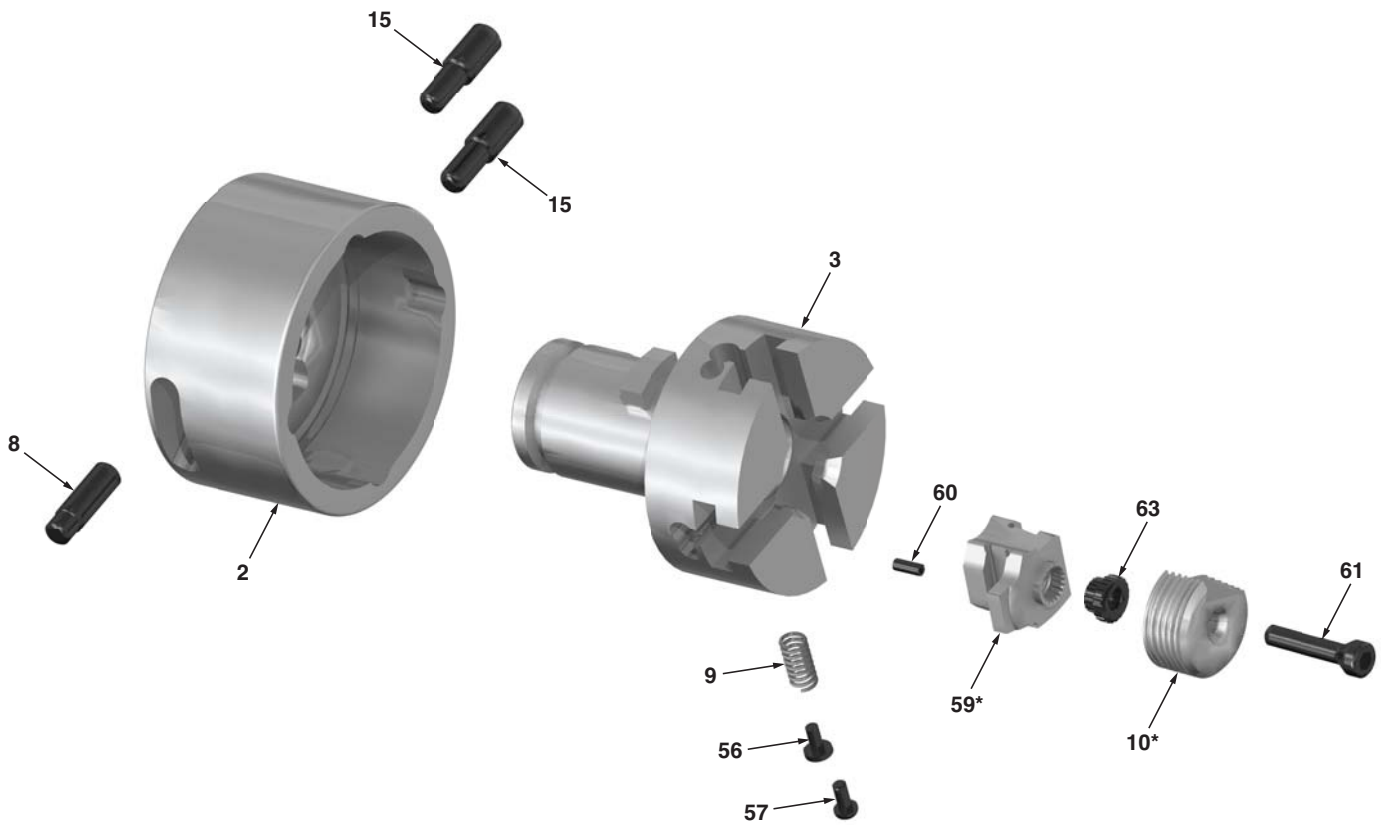

Part#	Description	Unit Reqd	9/16"	13/16"	1"	1-1/16"
			EDP No.	EDP No.	EDP No.	EDP No.
DRSA-1A	Body Assy	1	2992B-SA	2911B-SA	2909B-SA	2916B-SA
DRSA-2	Diecup	1	2951B SA	2912B SA	2910B SA	2917B SA
DRSA-8	Cup Rtnr Screw	1	1726	1726	1727	1727
DR-9	Chaser Spring	4	3233	3239	3244	3239
DR-15	Adjusting Screw	2	1014	1725	1499	3030
DR-56	Spring plunger for DR-9	4	3080	3080	3046	3080
DR-57	Spring plunger screw	4	3045	3045	3045	3045
DR-60	Pin in block	4	3247	3247	3247	3247
DR-61	Chaser screw		**	**	**	**
DR-63	Serrated brushing		**	**	**	**

* See Catalog pages 21-22 for available standard block and chaser sizes.

** See Catalog Page 19



RSVP Tooling, Inc.

Toll Free: 888-289-7787 • Direct: 815-725-3310

Fax: 815-725-3391 • Email: sales@rsvptooling.com

www.rsvptooling.com