

# Burnishing Tool SET 510



## Features

- Fixed tool head
- Can be adjusted up to  $\pm 10^\circ$  thanks to integrated setting options in the shaft
- To burnish ripples with cylindrical surfaces – limited cones and radii

## Recommendations

- Burnishing speed up to 200 m/min
- Feed rate up to 0.2 mm/U
- Workpiece measurement of 0.01 mm ( $\sim R_z 10$ ) and 0.02 mm ( $\sim R_z 20$ )
- It is recommended to use a cooling lubricant

## TOOL VERSIONS

Order No.	Tool holder designation	Basic shaft [mm]	Dimensions [mm]							Including shaft adapter [mm]
			a	b	c	d	e	f	x	
31002859	510-10U	10 x 10	10	10	110	16	30	18	9	12 x 12
										16 x 16
31002860	510-16U	16 x 16	16	16	119.5	20	39	25	13.5	20 x 20
										25 x 25

Sets delivered without diamond tip

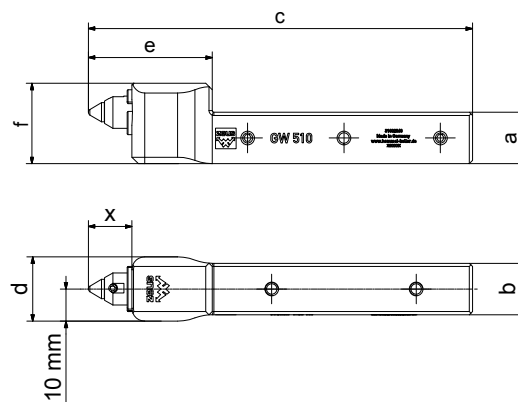
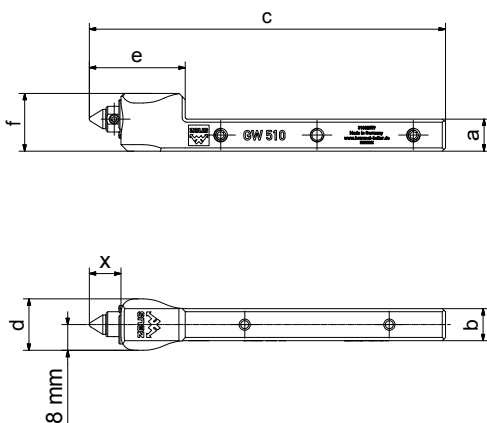

## DIAMOND TIP VERSIONS

Order No.	Tip radii [mm]
06TGW0008	0.4
06TGW0009	0.6
06TGW0010	0.8
06TGW0011	1.0

